



VISTAS architecture implementation in a multi-system integration bench



This project is co-funded by the European Union

This article and the work described below has been made in collaboration between TEMAI Ingenieros and Airbus Defence and Space.

TEMAI Ingenieros: Roberto Bussión, Javier Relaño, Luis Tovar.

Airbus Defence and Space: Santiago Rafael López Gordo, Emilio García, Jose Luis Galindo.

Abstract:

Future developments require an approach able to deal with virtual, hybrid and real equipment integration testing. Benches will be designed as live entities that can evolve during the different phases of the project, evolving from virtual integration to real equipment integration using the same bench. For this purpose, VISTAS EUROCAE (ED-247) standard approach is going to be demonstrated on an existing integration bench (traditional approach). VISTAS standard virtualize avionic signals -discrete, analog- and avionic buses -A429, CAN, AFDX...- on a standard Ethernet Bus. This standard includes also the possibility of failure injection. Benches architectures based on VISTAS provide more flexibility and enable important wiring reductions.

Key words: Virtual Testing, V-Model, VISTAS, Virtualization

Introduction. The V-Model for aircraft development

In the V-model (see Fig. 1), two sides can be distinguished. The left one, devoted to Design, and the Right one at which integration activities take place. The major issue related to this approach is that is necessary to wait until the system under test is designed, and the aircraft equipment manufactured, considering hardware and software, to perform the integration activities.

With the Virtual Testing approach, integration activities located at the right side of the V are moved to the left side, by using simulations, in other words: real aircraft equipment (HW/SW) are substituted by models (called Virtual Components) that are representative simulations of the equipment/system/system of systems under test.

The integration of these Virtual Components produces Virtual Test Benches.

So, Virtual Testing comprises the development and integration of Virtual Components and the related testing activity.

The message is clear, the fact of performing integration at the left side of the V model, by using models, allow detecting integration related failures at earlier stages of development, with the immediate effect related to time and cost. It has been

demonstrated that the time and cost to fix these failures at earlier stages of development, is lower if compared to the traditional approach. At the end test with real equipment –traditional approach- are necessary, but considering Virtual Testing, the number of issues detected are lower as the maturity at system level is higher.

VISTAS added value

VISTAS, which is a Standard for Virtual Interoperable Simulation for Tests of Aircraft Systems, allows the development of Virtual / Hybrid / Real benches with the possibility of performing integration at the earlier stages of the V model, with all the advantages described before.

Although the concept is not technologically a novelty, the importance of VISTAS is that it is a standard itself. Contributors come from different areas such as aircraft manufacturers, aircraft equipment manufacturers and Test System Support companies. All of them are working together and defining the standard. The revision ED 247A of it has been published by EUROCAE in March 2020.

VISTAS standard includes Virtual Components definition and protocols for interfaces standardization between test benches and Virtual components. A proper VISTAS implementation in a bench can provide the following advantages:

**This project has received funding from the Clean Sky 2 Joint Undertaking under the European Union's Horizon 2020 research and innovation programme under grant agreement No 831794. Project Acronym: IOVISTAS VIRTEST*

**This document reflects only the author's view and that the JU is not responsible for any use that may be made of the information it contains*



VISTAS architecture implementation in a multi-system integration bench



This project is co-funded by the European Union

Cost reduction:

- By allowing the integration at earlier stages through Virtual Components, discovering system errors and SW errors at the left part of the V, which is traduced in a lower cost of fixing them if compared with the traditional approach of integration at the right side of the V model.
- By reusing SW libraries of virtual test HW.
- By reducing the cost of bench development, based on an approach of VISTAS implementation at bench architecture by using the SO called VISTAS I/O bridges or VISTAS I/O boxes.

Product Quality:

- By improving the regression testing. In the regression testing, automation plays an important role, and combined with a VISTAS implementation at which virtual / hybrid and real scenarios can take place the results are a very flexible and automated environment which allows to perform regression testing with a high degree of coverage, which impacts at the end in the robustness and maturity of the system under test prior to be installed at aircraft.
- Providing a quick verification of system design changes, before HW/SW implementation at real equipment, by minimizing the number of iterations at aircraft equipment level (Ex. only SW/HW changes are implemented at real aircraft equipment when they have demonstrated functionality in a virtual way).

Another advantage is less development time, based on the possibility of the duplication of the virtual environments as they are SW based, and of course by performing integration testing at earlier stage without HW availability. Even it can be considered to distribute geographically development and testing.

VISTAS Architecture

VISTAS architecture is defined by two buses (see Fig. 2):

The first one is the ED-247 Data Bus, intended for transporting all functional data, which are:

- Avionics and aircraft system exchanges
- non-avionics data for environment exchanges

In this bus communication lines (avionic buses) are represented in a virtual way, and are used for connecting virtual components (simulations) and/or bridge components in the case of hybrid and/or real equipment benches.

A second bus is a Command-and-Control bus for operating ED-247 components in terms of configuration, state machine, network modification and health monitoring.

In a virtual configuration, the different Virtual Components are integrated through these two buses.

In a hybrid configuration, real equipment can be connected to VISTAS architecture by using an I/O box or a BRIDGE box. This box interacts with the real aircraft equipment and with the ED-247 data bus and Command and Control bus, and it is bi-directional. This element is composed by an I/O stage which is connected to the interface of the real aircraft equipment, and a HW/SW which is able to convert real aircraft buses and signals into VISTAS protocol virtualized signals and vice-versa. The key point in the development of these I/O boxes is the capability of performing the conversion from/to VISTAS Data Bus and real Avionic Buses and signals with the minimum delay.

In addition, some aircraft equipment manufacturers can consider prototypes with VISTAS interface for development purposes, so the usage of the I/O box can be avoided.

**This project has received funding from the Clean Sky 2 Joint Undertaking under the European Union's Horizon 2020 research and innovation programme under grant agreement No 831794. Project Acronym: IOVISTAS VIRTEST*

**This document reflects only the author's view and that the JU is not responsible for any use that may be made of the information it contains*

Finally, and moving towards an scenario with real aircraft equipment, the interaction of all the equipment can be achieved through VISTAS, by substituting real aircraft wiring by interconnection through VISTAS protocol. This approach enables the virtualization not only in terms of wiring, but also the virtualization of failure injection modules and patch panel modules which require a large

number of wires, manufacturing time and space in the bench. The key point in this approach is the level of representativeness comparing to real aircraft wiring and the delays inherent to a conversion from the real aircraft equipment interface to VISTAS architecture, which maybe today is not enough for obtaining credits for certification in all of the cases.

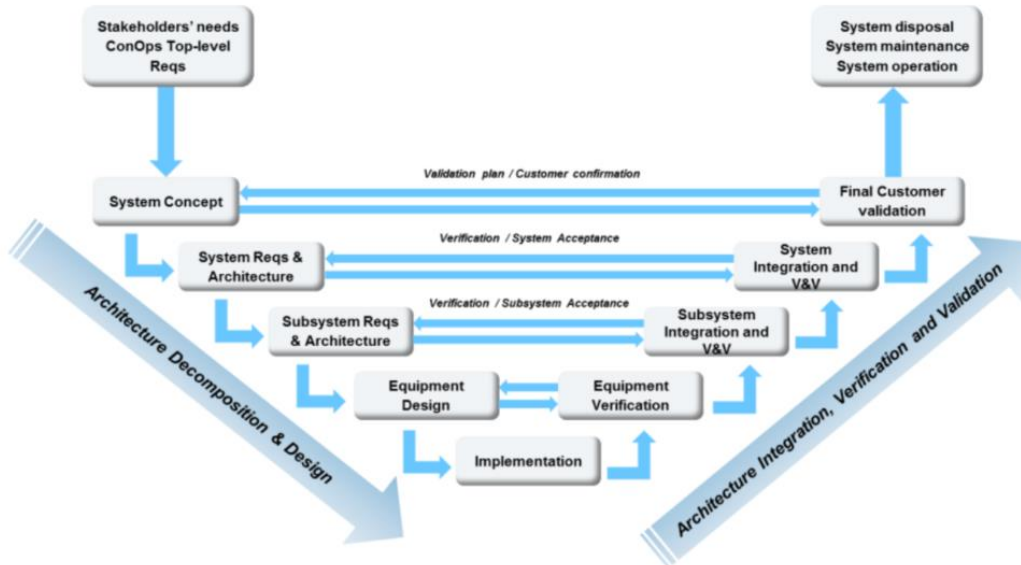

Fig. 1. V-model.

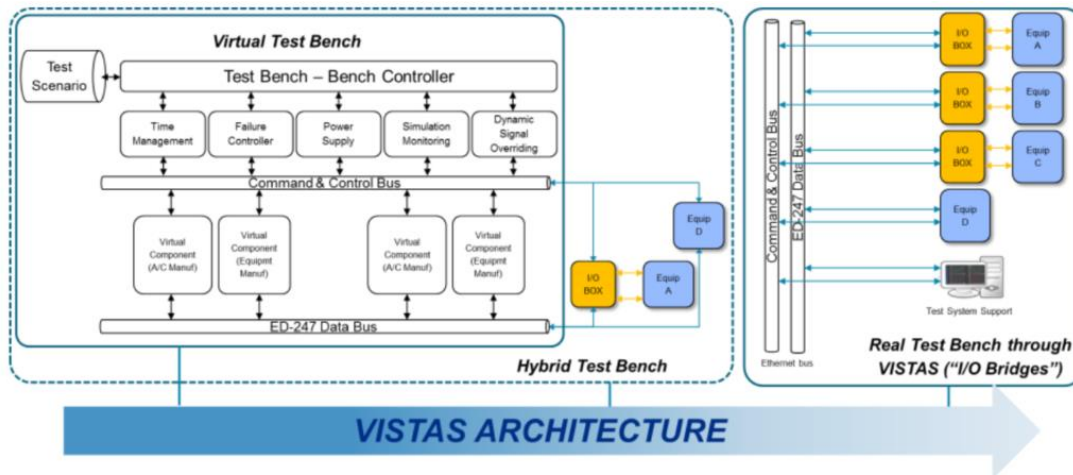

Fig. 2. VISTAS Architecture.

*This project has received funding from the Clean Sky 2 Joint Undertaking under the European Union's Horizon 2020 research and innovation programme under grant agreement No 831794. Project Acronym: IOVISTAS VIRTEST

*This document reflects only the author's view and that the JU is not responsible for any use that may be made of the information it contains



VISTAS architecture implementation in a multi-system integration bench



This project is co-funded by the European Union

Implementation of VISTAS concept in a real integrated test bench

In this chapter it is described the implementation of VISTAS concept in a real integrated test bench, which is Cleansky 2 integrated bench.

Cleansky 2 is the largest European research program, developing innovative, cutting-edge technologies, aimed at reducing CO₂, gas emissions...

One of them is related the use of Electromechanical actuators, with the intention of substituting hydraulic by electro mechanic actuators. For this purpose, an integrated rig has been developed based on the existing C295 platform. At this rig several systems are integrated such as: electrical, hydraulic, flight control system, cockpit, displays...

A project inside Cleansky 2 program is related to the implementation of VISTAS in the CS2 integrated rig. A call for proposal has been launched for this purpose.

Objectives

The objectives of this work are the following:

- To create a real demonstrator for VISTAS concept based on existing test means, and combining hybrid and real bench environments.
- To implement VISTAS protocol in a real bench with different signals and avionic buses to be virtualized such as A429, CAN, analog, discrete, serial, RVDT interfaces and including in addition simulation models.
- To assess the differences between real integration and virtual integration through VISTAS, specifically addressing the impact produced by the I/O or bridge boxes during conversion between real and virtualized environment.
- To develop the VISTAS capability into current Test System Supports available at the bench. In Cleansky 2 integrated bench are two different test systems support, one is an "In-house" solution called SEAS and the

other is a COTS solution provided by National Instruments.

- To establish a VISTAS based framework that allows to connect CS2 integrated bench with other existing benches at different locations (ex. avionics benches)
- To foster the OPEN architecture concept and connect different equipments/tools not present in the current bench that provides VISTAS interfacing functionality (UEI, AIDASS, SANDRA...)

Cleansky 2 integrated rig bench architecture

The Cleansky 2 integrated rig is composed by the following test means (see Fig. 3):

- Electrical rig, at which generation, conversion and distribution is integrated and tested shaping the electrical power generation system of the aircraft.
- Flight Control Computer bench, at which the two Flight Control computers are integrated and tested.
- Flight Test Instrumentation bench, at which the Data Acquisition System installed at real aircraft is integrated at rig environment.
- Flap Test Bench, at which High Lift Control Unit computer is integrated and tested.
- Cockpit and displays bench, used for cockpit systems integration: trim actuator, springs, displays; and for handling qualities evaluation, flight control laws evaluation and emergency interim procedures evaluation.
- Surfaces benches (for primary and secondary surfaces) at which integration between computer and actuator is achieved.
- Hydraulic rig for hydraulic system integration.

All of these benches can be operated in standalone mode, with the aircraft environment external to the equipment or system under test completely simulated, or

**This project has received funding from the Clean Sky 2 Joint Undertaking under the European Union's Horizon 2020 research and innovation programme under grant agreement No 831794. Project Acronym: IOVISTAS VIRTEST*

**This document reflects only the author's view and that the JU is not responsible for any use that may be made of the information it contains*

in integrated mode, by interconnecting the benches through real aircraft wiring. In addition, an additional level of integration can be reached by interconnecting the benches in terms of electrical and hydraulic power.

Using VISTAS approach all the benches are interconnected using Ethernet with VISTAS protocol implemented (see Fig. 4). The I/O boxes are based on the current Test System Support HW, as indicated before combining both “in-house” and COTS solutions, so it

has not been planned to develop specifically any HW devoted to VISTAS.

The “in-house” is based on SEAS and the COTS is based on National Instruments Compact Rio and PXI (this last for electrical rig).

The SW deployed on all these platforms is modified with the implementation of the VISTAS protocol for interconnection of the different benches.

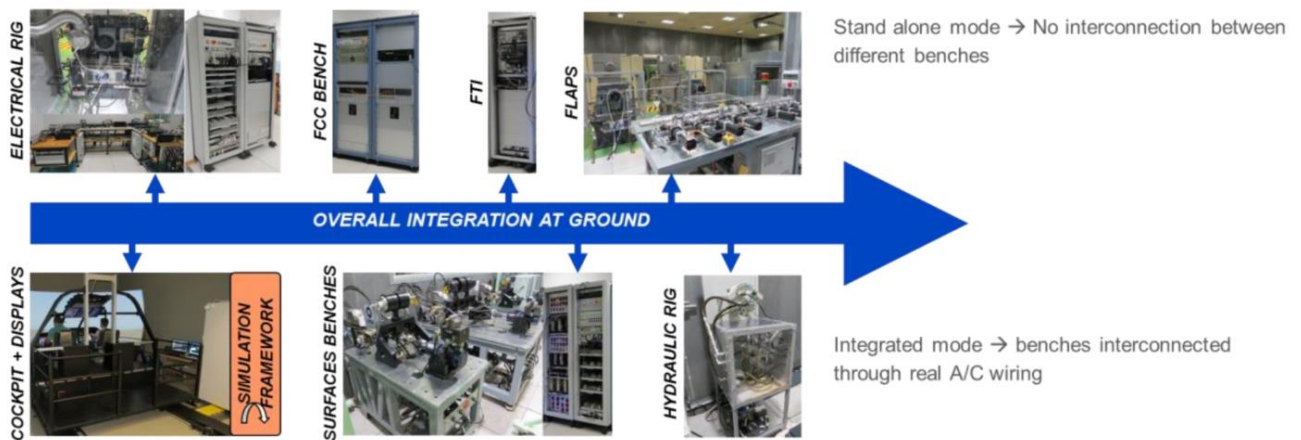

Fig. 3. Cleansky 2 Integrated Rig.

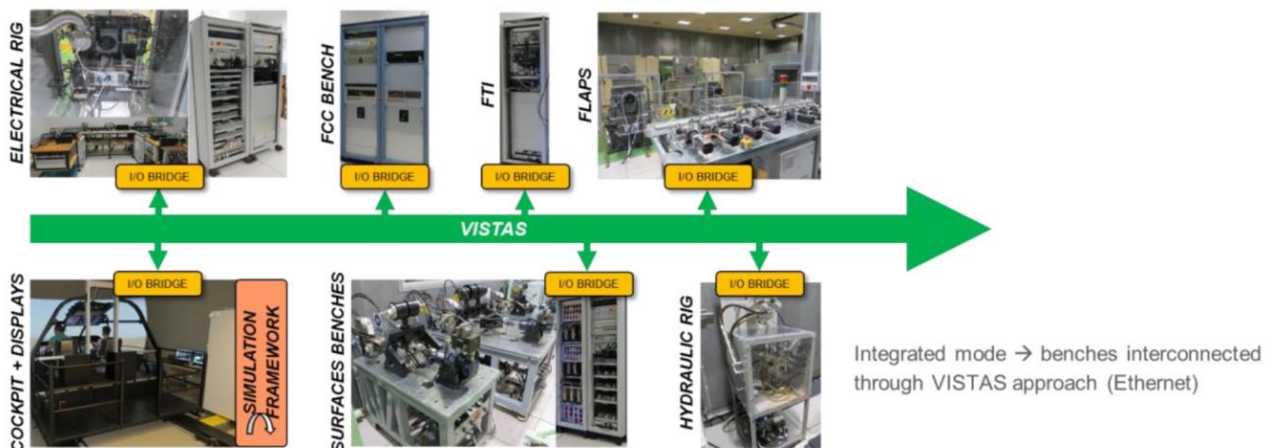

Fig. 4. Cleansky 2 Integrated Rig with VISTAS protocol implemented.

*This project has received funding from the Clean Sky 2 Joint Undertaking under the European Union’s Horizon 2020 research and innovation programme under grant agreement No 831794. Project Acronym: IOVISTAS VIRTEST

*This document reflects only the author's view and that the JU is not responsible for any use that may be made of the information it contains

SW components diagram

Every bench which is part of CS2 integrated rig has its own Test Support System, providing a distributed Test Support System when all the benches are working in integrated mode. The implementation of VISTAS is based on the development of a dynamic link library which is able to convert the Test Support System present at every bench into a I/O Bridge.

The objective of VISTAS implementation is to keep physically all the benches in stand/alone configuration, in other words, without considering all the interconnections between benches at signal level, and substitute this by an interconnection through VISTAS protocol.

The dynamic link library with some functions has been developed in C++. The dynamic link library which has been developed is platform agnostic, as it can work with the Windows platform present at "in-house" test support systems such as SEAS, or it can work also with Linux platform present at National Instruments COTS platform.

The working principle is the following (see Fig. 5):

- The I/O Bridge interacts with the real aircraft equipment through signal/bus input output stage.
- The I/O Bridge is provided with the ECIC file, at which the VISTAS configuration is stated. It is necessary to remark that for complex benches this ECIC file (one per I/O Bridge) may be provided with the aid of a Resolver SW application. In our case it has been done manually without resolver application. In the ECIC file is included the following information: IP, ports, channel assignation, packetization strategy, timestamps, and header... all the data necessary to virtualize the signals in an optimized way.
- Using the different functions of the dll the frames are generated and passed through Ethernet over VISTAS protocol.

Of course, this working principle is bidirectional.

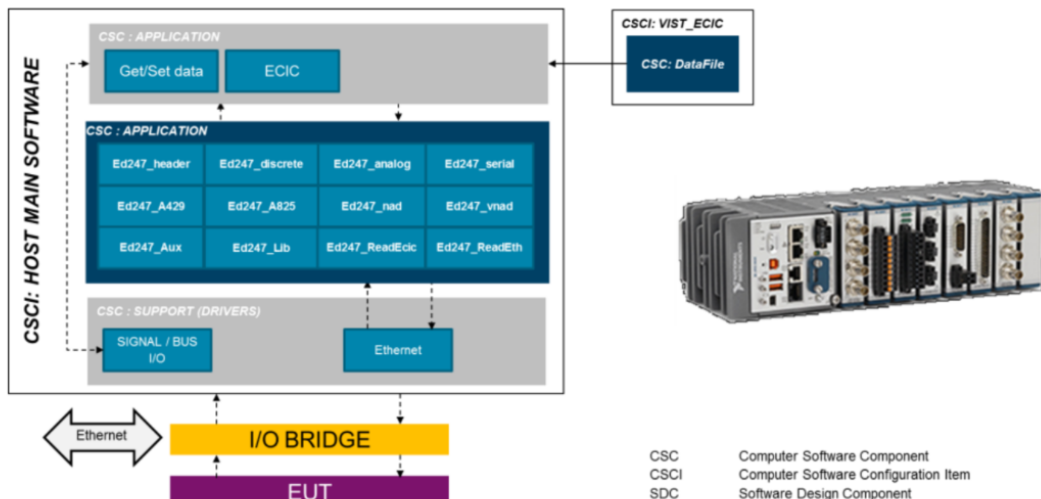

Fig. 5. SW components diagram.

*This project has received funding from the Clean Sky 2 Joint Undertaking under the European Union's Horizon 2020 research and innovation programme under grant agreement No 831794. Project Acronym: IOVISTAS VIRTEST

*This document reflects only the author's view and that the JU is not responsible for any use that may be made of the information it contains

Status of the activities

The current status regarding VISTAS implementation at CS2 Integrated Rig is the following:

- The development of the ED247 library is done for the avionic buses used at CS2 integrated rig, which are: A429, CAN BUS, Analog, Discrete, and RVDT.
- Generation of configuration files is done in a manual way.
- VISTAS performance testing activities are taking place at CS2 integrated lab and other available benches.
- Implementation on existing HW is achieved at National Instruments cRIO platform, but it is still pending other platforms present at CS2 integrated bench such as National Instruments PXI and PCI platform at SEAS "in-house" test system support.
- And finally, the pending activities are Monitoring/recording SW, development of resolver SW and bench manager SW is pending.

Performance tests

A429 Virtualization through VISTAS has been tested at CS2 Integrated lab with different configurations as indicated in the table (see Fig. 6), by the interconnection through VISTAS of different aircraft equipment.

Current National Instruments compact RIO present at the bench has been used as VISTAS I/O bridges.

No packetization strategy has been considered, which means one UDP packet per A429 label.

In all the cases the latency average value is very low if it is compared by the update rate of the aircraft equipment A429 buses, which in principle enables the multisystem integration, without significant delays that can affect to the behavior of the system/multisystem under test.

It has been observed different latencies that are explained by the different model of switch used for the test.

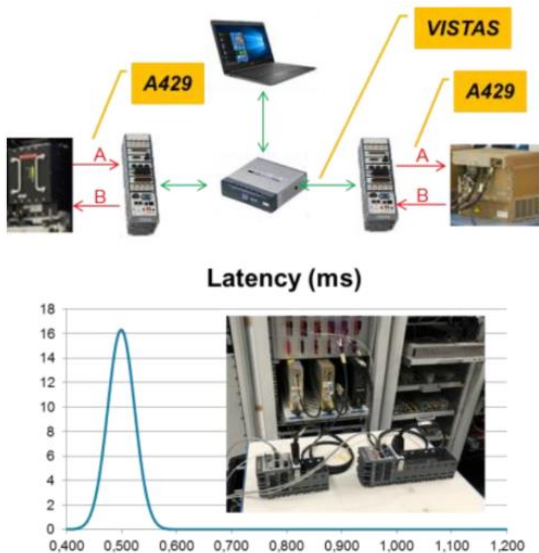

Test case	Direction	N° of buses	Speed (Kbps)	Labels	Rate (ms)	Latency (us)	Switch
BCU/HERCU	A	2	12,5	4	16	750	LinkSys SD205
				6	128	750	
	B	4	100	9	16	750	
				2	1024	750	
ACE/ACE	A	2	100	4	8	500	CISCO 2950
	B	2	100	4	8	500	
FCC/ACE	A	1	100	3	16	500	CISCO 2950
			100	1	32	500	
TEFU/PU	A	1	100	14	250	500	CISCO 2950

Fig. 6. A429 performance tests.

*This project has received funding from the Clean Sky 2 Joint Undertaking under the European Union's Horizon 2020 research and innovation programme under grant agreement No 831794. Project Acronym: IOVISTAS VIRTEST

*This document reflects only the author's view and that the JU is not responsible for any use that may be made of the information it contains

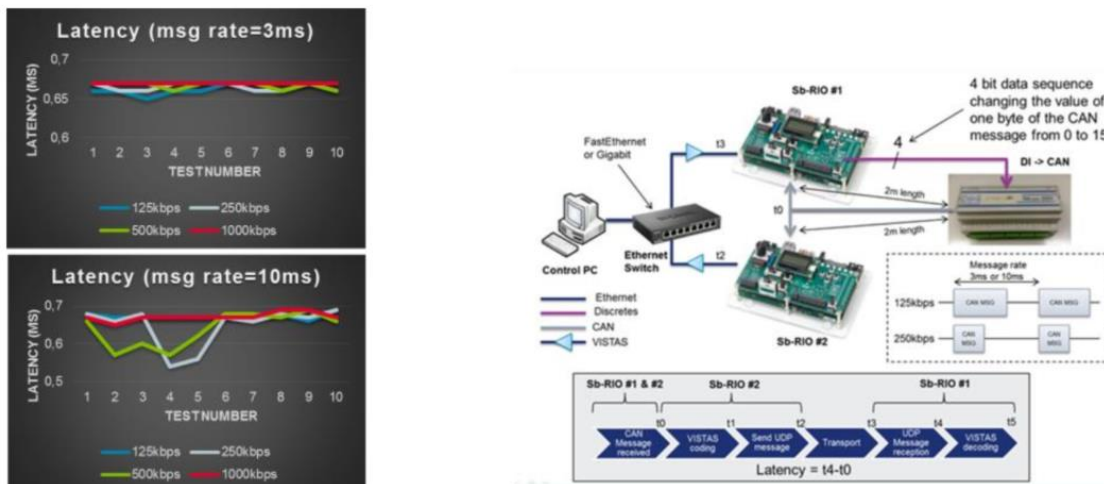

Fig. 7. SW components diagram.

CAN Virtualization through VISTAS has been tested, using a National Instruments SB-RIO demonstration kit as VISTAS I/O bridge, for hosting the VISTAS SW (see Fig. 7).

Different CAN BUS speeds, from 125Kbps to 1000kbps, and different message rates (3msec and 10msec) have been considered to set up the test case list. For each test case 10 tests have been considered with duration of 10 seconds.

In all the cases the latency average value is constant and independent on the CAN bus speed.

Conclusion

And finally, and as a conclusion, the key messages based on our expectations related to integration with VISTAS are summarized:

- It has been presented the VISTAS concept as a future concept for bench architecture, as a tool for virtual testing.
- It has been provided an overview of the VISTAS implementation at CS2 integrated Rig, and its current status, focusing on the performance tests performed for A429 and CAN buses.
- It can be evaluated the necessity of real aircraft wiring for integration. If finally, is necessary, at least,

VISTAS integration provides the possibility of delaying real aircraft wiring manufacturing at rig until a reasonable level of maturity has been reached through VISTAS integration, which will contribute to cost reduction as the number of modifications and/or reworks over real aircraft wiring will be very limited. If finally real aircraft wiring is not necessary, the next step is to check if certification credits can be obtained from VISTAS approach that is not 100% representative of aircraft, but provides integration capabilities.

- It can be assessed if the signal exchange between different elements is representative using VISTAS, because at the end, the savings in terms of wirings, patch-panels, and fault insertion HW devices... are based on bidirectional conversions from acquired/issued signals to VISTAS protocol, and the conversion itself provides some delay.

References

[1] EUROCAE ED-247A: Technical Standard of Virtual Interoperable Simulation for Tests of Aircraft Systems in Virtual or Hybrid Bench (March 2020).

*This project has received funding from the Clean Sky 2 Joint Undertaking under the European Union's Horizon 2020 research and innovation programme under grant agreement No 831794. Project Acronym: IOVISTAS VIRTEST

*This document reflects only the author's view and that the JU is not responsible for any use that may be made of the information it contains